

# ***CRYSTAL FIRES***

VALENTINES BUILDING  
BECHERS DRIVE  
AINTREE RACECOURSE  
BUSINESS PARK  
LIVERPOOL  
MERSEYSIDE L9 5AY

## **DIAMOND DECORATIVE INSET GAS FIRE**

THIS APPLIANCE IS CAT I<sub>2H</sub>  
FOR USE WITH NATURAL GAS ONLY  
G20 AT 20mbar  
IN G.B. AND I.E.

### **INSTALLATION & SERVICING BOOK USERS INSTRUCTIONS**

ISSUE 1

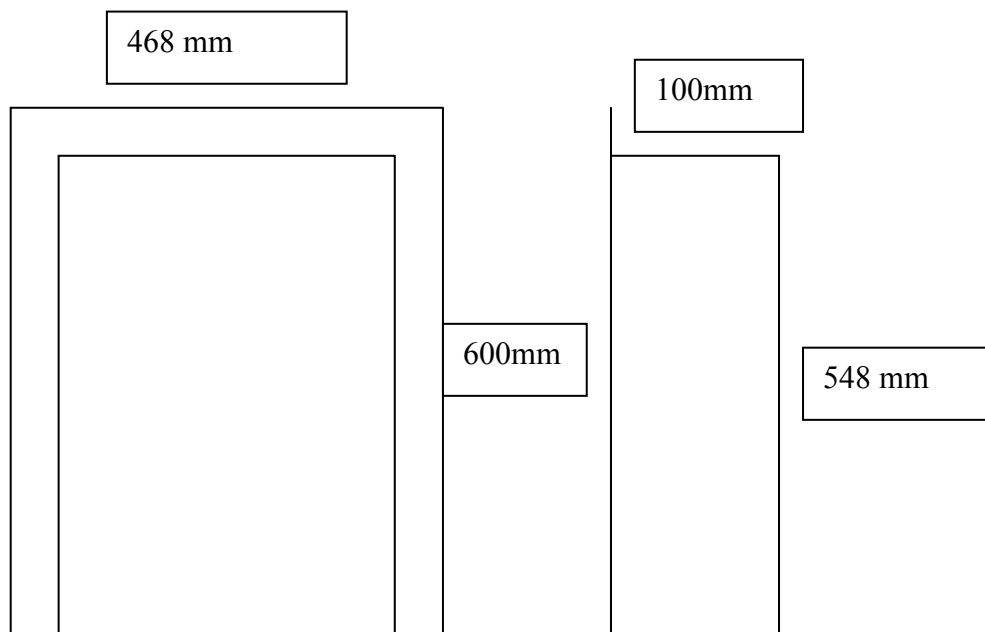

## **SIZES INC TRIM**

**PLEASE READ THESE INSTRUCTIONS CAREFULLY BEFORE YOU  
START INSTALLING THE APPLIANCE. KEEP THIS BOOKLET HANDY  
FOR FUTURE REFERENCE**

**Issue 1**

.....TECHNICAL DATA.....

**HEIGHT. 600mm**  
**WIDTH. 468mm**  
**WEIGHT. 15kg**

**GAS TYPE: G20 NATURAL**  
**GAS PRESSURE : 20 mbar**  
**CONNECTION:8mm OD TUBE**

**SPARK GAP: 2.5-4mm**

**INJECTOR: TYPE CAT 82/420 BRAY**  
**HEAT INPUT (GROSS)**  
**HIGH: 6.5KW**  
**LOW: 4.1KW**

**CAT:12h**  
**DATA LABEL LOCATION FRONT BOTTOM SECTION OF APPLIANCE**

**ISSUE 1**

## INSTALLATION GENERAL

### IMPORTANT NOTES

THE DIAMOND IS DESIGNED AND TESTED TO THE REQUIREMENTS OF BS5258 P16 AND IS FITTED WITH AN ATMOSPHERE SENSING DEVICE  
THE SUPER HEATRAVE CAN ONLY BE USED IN CONJUNCTION WITH THE FOLLOWING CHIMNEYS :

CONVENTIONAL BRICK OR STONE CHIMNEY. A PRE CAST FLUE CONFORMING TO BS 1289 PT.1 OR A METAL FLUE BOX CONFORMING TO BS715, FURTHER DETAILS ARE COVERED LATER. A NON COMBUSTABLE HEARTH MUST BE PROVIDED TO COMPLY WITH THE BUILDING REGULATIONS OR A SUITABLE PROPRIETARY FIRE SURROUND WITH A 100 DEGREES C RATING.

THE CHIMNEY OR FLUE (**UNLESS NEW** ) MUST BE SWEEPED BEFORE INSTALLATION IF IT HAS BEEN USED FOR SOLID FUEL

### \*INSTALLER

THE APPLIANCE MUST BE INSTALLED BY A COMPETENT PERSON , IE A CORGI REGISTERED INSTALLER IN ACCORDANCE WITH THE CURRENT EDITION OF THE GAS SAFETY (INSTALLATION AND USE ) REGULATIONS OR THE RULES IN FORCE. FAILURE TO DO SO COULD LEAD TO PROSECUTION

### \*REGULATIONS

THE FOLLOWING ARE THE RELEVANT CODES OF PRACTICE AND BRITISH STANDARDS:  
BS5781 PART 2 1991, BS8303 1986, BS 5440 PART 1 1990 , BS1251 1987, BS 6891 1988 , BS 6461 PARTS 1 & 2 1984 , BS 715 1989 , BS 1289 PART 1 1986

THE BUILDING REGULATIONS ISSUED BY THE DEPARTMENT OF THE ENVIRONMENT  
THE BUILDING STANDARDS (SCOTLAND) (CONSOLIDATION) REGULATIONS ISSUED BY THE SCOTTISH DEVELOPMENT OFFICE

### \*VENTILATION

#### **GREAT BRITAIN**

NO SPECIAL VENTILATION BRICKS OR VENTS ARE NORMALLY REQUIRED INTO THE ROOM CONTAINING THE APPLIANCE, PROVIDED NORMAL ADVENTITIOUS ROOM VENTILATION EXISTS. THE INSTALLER MUST SATISFY THIS POINT BY CARRYING OUT A MANDATORY SPILLAGE TEST

#### **IRELAND**

PURPOSE PROVIDED VENTILATION MUST BE PROVIDED AND MUST HAVE A MINIMUM FREE AREA OF 100 CM<sup>2</sup>

### \*WARNING

**THIS APPLIANCE HAS A NAKED FLAME, AS WITH ALL SUCH FIRES IT IS RECOMMENDED THAT A FIREGUARD SHOULD BE USED FOR THE PROTECTION OF CHILDREN, THE ELDERLEY AND INFIRM. FIRE GUARDS SHOULD CONFORM TO BS 6539 (1984) ( FIREGUARDS FOR USE WITH SOLID FUEL APPLIANCES)**

## INSTALLATION REQUIREMENTS

### PRE CAST FLUE

A PRE CAST FLUE CONFORMING TO THE REQUIREMENTS OF BS 1289 PART 1. FOR DETAILS OF THE DIMENSIONS REQUIRED TO LOCATE POSITION OF THE APPLIANCE WITHIN THE OPENING / STARTER BLOCKS SEE (FIG.2) WITH A MINIMUM OF 3 METRES EFFECTIVE HEIGHT.

A SUITABLE FIRE RESISTING FIRE SURROUND WILL BE REQUIRED, SPACED OUT TO THE CORRECT THICKNESS BETWEEN THE REAR OF THE FLUE BLOCK BREAST AND THE REAR OF THE APPLIANCE FLANGE.

**NOTE.**

AN INSPECTION SHOULD BE MADE TO ENSURE THAT THE INTERNAL WALLS OF THE FLUE ARE CLEAR OF MORTAR FANGS PRIOR TO INSTALLING THE APPLIANCE.

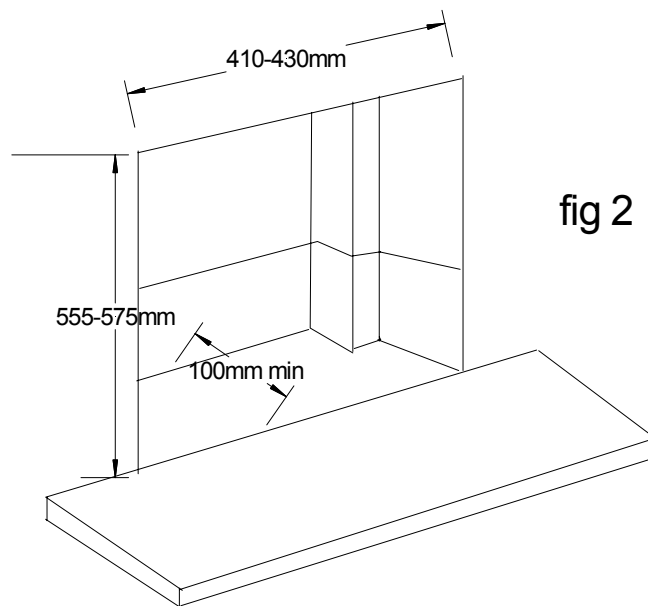

A 25mm SPACER CAN BE FITTED TO ALLOW MORE DEPTH IF REQUIRED USING THE FOLLOWING PROCEDURE.  
MARK POSITION OF FLANGE HOLES, DRILL AND PLUG AND FIX SPACER TO FIREPLACE ENSURING A GOOD SEAL IS MADE BETWEEN SPACER AND FIREPLACE USING FOAM SEAL SUPPLIED. THEN SCREW FIRE TO SPACER SEALING WITH FOAM SEAL SUPPLIED AND SCREWS SUPPLIED WITH SPACER

## INSTALLATION REQUIREMENTS

### LOCATION AND FLUES

#### CONVENTIONAL CHIMNEY

A CONVENTIONAL BRICK OR STONE CHIMNEY AS USED FOR A SOLID FUEL APPLIANCE WITH A MINIMUM EFFECTIVE CROSS SECTIONAL DIMENSION OF 225 \* 225 mm (9 \* 9 ins) WITH A MINIMUM OF 3 METRES EFFECTIVE HEIGHT.

A LINED FLUE WITH A MINIMUM DIAMETER OF 175 mm (7ins), WITH THE FIREPLACE COMPONENTS CONFORMING TO BS 1251

A BUILDERS OPENING A MINIMUM OF 555mm HIGH TO MAXIMUM 575 mm HIGH AND MINIMUM 410 mm TO MAXIMUM 430 mm WIDE, WITH A MINIMUM DEPTH OF 200 mm TO ALLOW SUFFICIENT VOLUME OF DEBRIS COLLECTION. TO OBTAIN THIS DEPTH IT IS NECESSARY TO REMOVE THE CHAIRBRICK.

ANY PERMANENT FLUE RESTRICTION OR VARIABLE DAMPERS MUST BE REMOVED OR LOCKED FULLY OPEN

THE CHIMNEY MUST BE SWEEPED PRIOR TO INSTALLATION IF NOT NEW.

THE CHAIRBRICK MUST BE REMOVED ON ALL INSTALLATIONS.

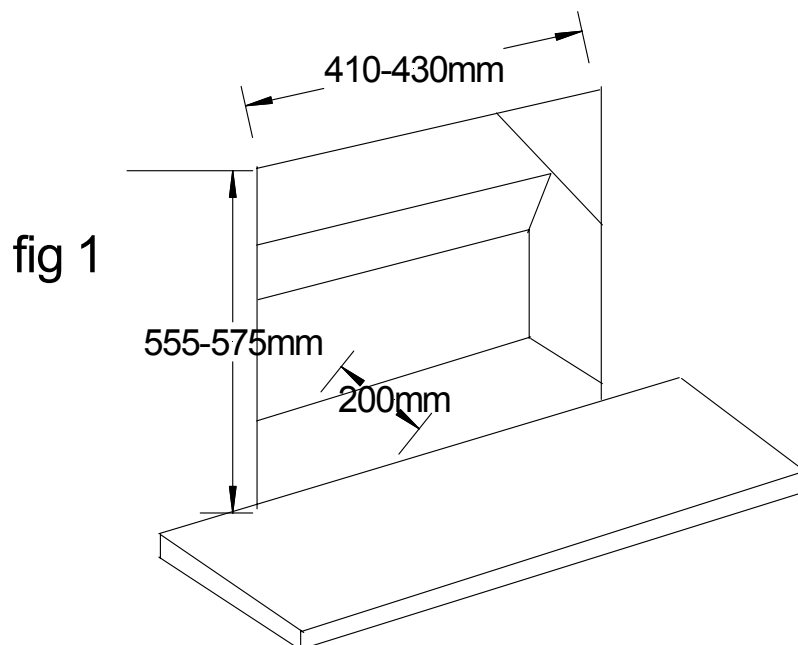

**INSTALLATION REQUIREMENTS**  
**5 " FLUE PIPE AND STARTER BOX**

A DOUBLE WALLED SELKIRK RECESSED FLUE BOX BUILT TO THE REQUIREMENTS OF BS 715 WITH AN INSULATED FLUE HAVING A MINIMUM DIAMETER OF 125mm (5") AND A MINIMUM EFFECTIVE OVERALL HEIGHT OF 3 METRES (10ft)

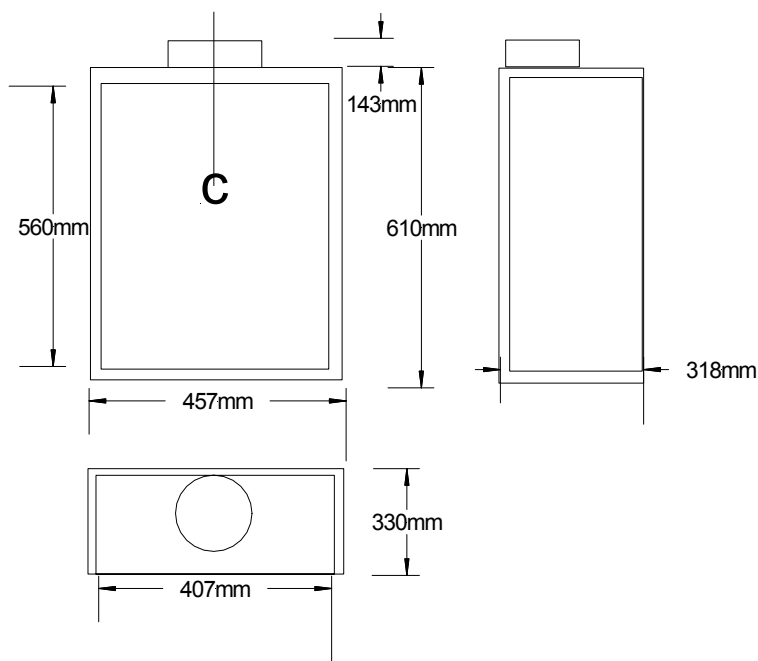

**RECESSED GAS FLUE BOX DIMENSIONS (NOT INCLUDING FIBREGLASS INSULATION)**

**NOTE**

THE METAL FLUE BOX MUST BE INSULATED WITH FIBRE GLASS OR EQUIVALENT TO A THICKNESS OF 25 mm.

**NOTE**

WHERE INSTALLATION IS FOR A METAL FLUE BOX, THE SURROUND MUST HAVE A TEMPERATURE RATING OF 150 DEGREES C .

**NOTE**

IF THE FLUE BOX IS TO BE USED WITH AN EXISTING BRICK OR STONE CHIMNEY A 125 mm (5") MINIMUM DIAMETER FLUE LINER CONFORMING TO BS 715 MAY BE USED.

**NOTE**

A BRICK CHAMBER TO THE SIZES IN FIG 1. IN AN EXISTING BRICK OR STONE CHIMNEY A 125 mm (5") MINIMUM DIAMETER FLUE LINER CONFORMING TO BS715 MAY BE USED, PROVIDING IT IS SEALED AT THE TOP AND BOTTOM OF THE EXISITNG BRICK OR STONE CHIMNEY.

**NOTE**

ANY OF THE ABOVE FLUES MUST NOT BE RESTRICTED BY DAMPERS OR REGISTER PLATES. THE FLUE MUST SERVE ONLY THE APPLIANCE AND NOT HAVE ANY BRANCHES OR TRAPA WHICH MAY IMPEDE THE NATURAL DRAUGHT. IF ANY TERMINAL IS FITTED IT MUST BE SUITABLE FOR THE PURPOSE.

### FRONT FACE SEAL

THE FRONT FACE MUST BE FLAT TO ENSURE THAT A GOOD SEAL IS FORMED BETWEEN THE REAR AND BASE OF THE APPLIANCE AND THE CHIMNEY TO AVOID ANY REDUCTION OF NATURAL DRAUGHT.

### HEARTH.

A NON COMBUSTIBLE HEARTH MUST BE PROVIDED BENEATH THE APPLIANCE WITHIN THE FIREPLACE OPENING.

A FIRE RESISTING HEARTH MUST ALSO BE PROVIDED SYMMETRICALLY DISPOSED ABOUT THE FIREPLACE OPENING A MINIMUM THICKNESS OF 12 mm WITH THE PERIMETER 50mm ABOVE THE FLOOR LEVEL.

THE WIDTH MUST EXTEND A MINIMUM OF 150mm EITHER SIDED OF THE FIREPLACE OPENING AND A DEPTH OF 315mm

FROM THE FRONT OF THE FUEL BED.

ANY COMBUSTIBLE MATERIAL ABOVE THE OPENING MUST BE REMOVED UP TO A HEIGHT OF 1 METRE ABOVE THE HEARTH LEVEL.

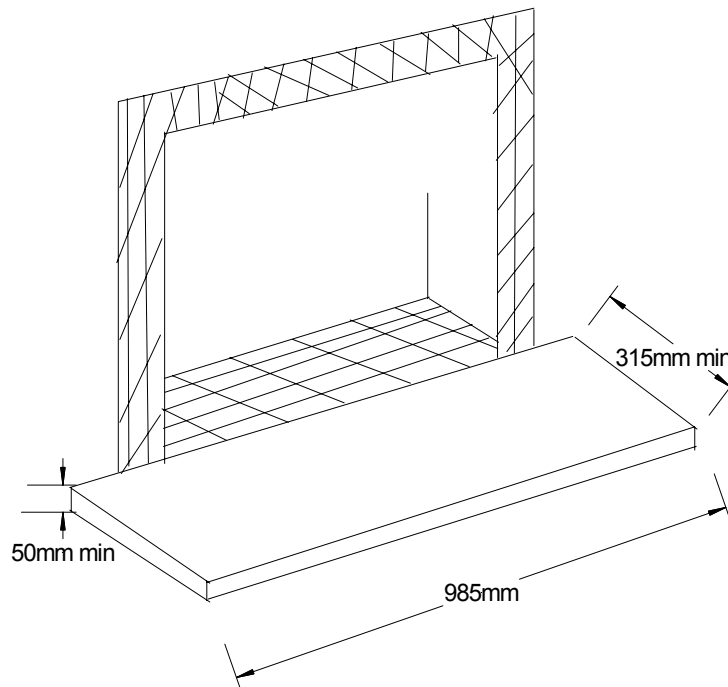

fig 4

### INSTALLATION REQUIREMENTS PURPOSE BUILT HEARTH & SURROUND

PURPOSE BUILT SUPERIMPOSED FIRE RESISTANT HEARTH AND BACK PANELS, SPECIFIED AS SUITABLE BY THE MANUFACTURER MAY BE USED, OR A SUITABLE PROPRIETARY FIRE SURROUND WITH A 100 DEGREES C RATING.

### SOFT FURNISHINGS

CARE SHOULD BE TAKEN TO PREVENT ANY DAMAGE BEING CAUSED TO SURROUNDING SOFT FURNISHINGS OR DECORATION .E.G. MANY EMBOSSED VINYL WALL COVERINGS MAY BECOME DISCOLOURED IF PLACED TOO CLOSE TO THE APPLIANCE.



## CLEARANCES

### SHELVES

MINIMUM CLEARANCE FROM HEARTH TO UNDERSIDE OF COMBUSTABLE SHELF MUST BE 800 mm PROVIDED SHELF DEPTH IS 150mm OR LESS

WHEN THE SHELF DEPTH IS INCREASED BY INCREMENTS OF 12.5 mm GREATER THAN 150 mm ADD 25 mm TO THE 800 mm MINIMUM CLEARANCE.

## SIDE OF FIRE

MINIMUM WIDTH BETWEEN VERTICAL SIDES OF COMBUSTABLE SURROUND SHOULD NOT BE LESS THAN 800 mm PROVIDED FIRE IS CENTRAL TO SURROUND AND SIDES DO NOT PROJECT MORE THAN 150 mm.

WHEN VERTICAL SIDE FORWARD PROJECTION IS INCREASED BY 12.5 mm ADD 50 mm TO INSIDE WIDTH OF SURROUND.

### NOTE.

WHEN FIRE IS FITTED THIS GIVES A MINIMUM SIDE CLEARANCE OF 150 mm.

## INSTALLATION STEPS

### CHECK FLUE

CHECK THAT THE CHIMNEY CONFORMS TO THE REQUIRED SPECIFICATIONS AS PREVIOUSLY STATED

EXAMINE THE CONDITION AND CARRY OUT ANY REMEDIAL WORK. IF THE FLUE HAS BEEN USED FOR SOLID FUEL IT SHOULD BE SWEEPED AND A SMOKE TEST CARRIED OUT TO CHECK THAT SATISFACTORY SMOKE CLEARANCE HAS BEEN ESTABLISHED

IF ALL THE SMOKE IS NOT DRAWN INTO THE FLUE, PRE HEAT THE FLUE WITH A BLOW TORCH OR SIMILAR AND RE CHECK. IF THERE IS ANY UNCERTAINTY EXAMINE FOR THE CAUSE AND IF NECESSARY SEEK EXPERT ADVICE.

## GAS SUPPLY

IT IS RECOMMENDED A CONCEALED CONNECTION IS MADE USING RIGID OR SEMI RIGID TUBING, ON TO THE LEFT SIDE OF THE UNIT TAKING INTO ACCOUNT THE REQUIREMENTS OF BS 6891 1988 DEALING WITH ENCLOSED PIPES.

**AFTER CONNECTING THE SUPPLY PIPE , MAKE SURE THE PIEZO OPERATES CORRECTLY AND DOES NOT FOUL ON THE GAS SUPPLY PIPE.**

A SUITABLE ISOLATING COCK SHOULD ALWAYS BE FITTED IN THE SUPPLY FEED TO THE FIRE TO FACILITATE SERVICING.

## SECURE FIRE TO THE FIREPLACE

MARK POSITION OF FLANGE HOLES, DRILL AND FIX AND PLUG FIRE TO FIREPLACE ENSURING A GOOD SEAL IS MADE BETWEEN FIREBOX AND FIREPLACE USING FOAM SEAL SUPPLIED.

## INSTALLATION STEPS

### CHECKING GAS PRESSURE AND SOUNDNESS

REMOVE THE PRESSURE TEST POINT SCREW FROM THE INLET ELBOW AND CONNECT PRESSURE GAUGE.

TURN ON GAS TO APPLIANCE.

ROTATE THE CONTROL TO THE IGNITION POSITION AND PUSH IN TO ALLOW THE AIR IN THE PIPEWORK TO BE PURGED.

PUSH IN PIEZO IGNITION SWITCH

CHECK THAT THE ELECTRODE IS SPARKING.

CONTINUE SPARKING UNTIL PILOT IGNITION IS ESTABLISHED.

TURN THE GAS CONTROL KNOB ON TO THE HIGH POSITION AND ALLOW TO RUN FOR FIVE MINUTES.

CHECK THE INLET PRESSURE IS 20 mbar. +/- 1mbar  
CHECK FOR GAS SOUNDNESS.

TURN OFF GAS SUPPLY, DISCONNECT PRESSURE GAUGE AND REPLACE PRESSURE TEST POINT SCREW.

### COAL BED LAYOUT

**PERIODICALLY SMALL DEPOSITS OF SOOT MAY GATHER ON THE COALS AND BURNER, THIS MUST BE REMOVED BY REMOVING COALS, AND BRUSHING OR VACUUMING ANY DEPOSITS, THEN COALS USING THE FOLLOWING PROCEDURE.**

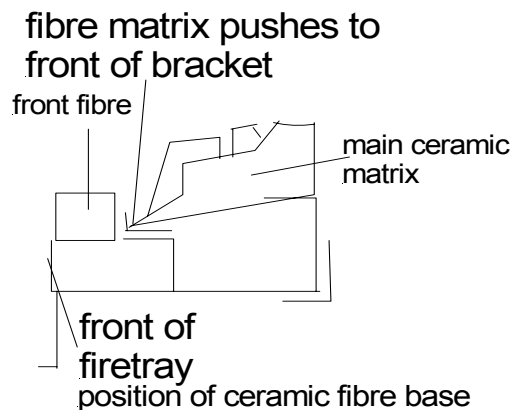

**MAIN BASE COME PACKED IN BOX WITH FIRE**

**DIAMOND RANDOM FUEL LAYOUT**  
**SLIMLINE RANDOM FUEL PIECES LAYOUT**  
**(ALSO COMES IN GREY AND BUFF COLOURS)**



SIX RANDOM FUEL PIECES SIT AS SHOWN ON TOP OF FRONT FIBRE PIECE.  
NOTE: THEY MAY HAVE TO BE TURNED SLIGHTLY TO ENSURE ENOUGH ROOM  
IS AVAILABLE FOR THEM ALL TO FIT CORRECTLY



THE NEXT FOUR FUEL PIECES SIT ON TOP OF FIRST PIECES AS SHOWN SITTING  
BETWEEN EACH OF THE FRONT PIECES



FINAL MIDDLE PIECE IS FITTED TO RIGHT  
FOUR RANDOM FUEL PIECES SIT AS SHOWN BETWEEN THE MIDDLE RANDOM FUEL  
PIECES FINISHING THE LAYOUT

## INSTALLATION STEPS

### TEST FOR SPILLAGE

CHECK FOR SATISFACTORY CLEARANCE OF COMBUSTION PRODUCTS

CLOSE ALL DOORS AND WINDOWS IN THE ROOM CONTAINING THE FIRE

TURN ON GAS SUPPLY , LIGHT THE FIRE AND SET THE CONTROLS TO HIGH

LEAVE THE FIRE BURNING FOR FIVE MINUTES AND INSERT A LIGHTED SMOKE MATCH ON A  
VERTICAL PLANE  
20 mm DIRECTLY UNDER FRONT EDGE OF CANOPY AND 75mm FROM EITHER SIDE OF THE OPENING  
(SEE DRAWING )

ALL THE SMOKE MUST BE DRAWN INTO THE FLUE.

IF SPILLAGE OCCURS ALLOW A FURTHER TEN MINUTES.

SHOULD SPILLAGE STILL OCCUR TURN OFF THE FIRE AND SEEK EXPERT ADVICE

IF AN EXTRACTOR FAN IS SITUATED IN THE ROOM THIS TEST SHOULD BE REPEATED WITH THE FAN  
RUNNING

IF THERE IS A CONNECTED ROOM WITH AN EXTRACTOR FAN , THE TEST SHOULD BE REPEATED  
WITH ALL THE DOORS TO THAT ROOM OPENED AND THE EXTRACTOR FAN RUNNING.

INSTALLATION STEPS
--------------------

**FITTING TRIMS**

FIT THE TRIM WITH FOUR MAGNETS PLACED ON THE VERTICAL SIDE FLANGES OF THE FIREBOX  
(ONE AT THE TOP AND ONE AT THE BOTTOM 0

OFFER THE BRASS TRIM UP AND PUSH INTO POSITION

PLACE FRET CENTALLY IN FRONT.

**INSTRUCT USER**

**IMPORTANT : THIS APPLIANCE IS FITTED WITH AN OXYGEN DEPLETION SENSOR INCORPORATED INTO THE PILOT BODY. SHOULD THE FIRE REPEATEDLY EXTINGUISH ITSELF THEN SPECIALIST ADVICE SHOULD BE SOUGHT, AS THIS MAY INDICATE SPILLAGE INTO THE ROOM OF COIMBUSTION PRODUCTS.**

**WARNING**

**THE OXYGEN DEPLETION SYSYTEM MUST NOT BE ADJUSTED BY INSTALLER**

**THE OXYGEN DEPLETION SYSTEM MUST NOT BE PUT OUT OF OPERATION**

**WHEN REPLACING OXYGEN DEPLETION SYSTEM ONLY ORIGINAL MANUFACTURERS PARTS SHOULD BE USED**

DEMONSTRATE THE LIGHTING AND EXTINGUISHING PROCEDURES TO THE USER AND REMOVAL AND REFITTING OF THE BRASS TRIM FOR CLEANING.

THE APPLIANCE SHOULD BE OPERATED WITH THE GAS CONTROL NOT TURNED ON MORE THAN LOW FOR THE FIRST FIVE HOURS OF USE TO ALLOW THE FIBRE COALS TO CURE SLOWLY.

THE CURING EFFECT OF HEATING THE COALS AND OTHER CERAMICS COMPONENTS WILL CAUSE AN INITIAL ODOUR.

THE APPLIANCE SHOULD BE SERVICED ANNUALLY BY A COMPETENT PERSON IN ACCORDANCE WITH THESE INSTRUCTIONS AND THE APPLIANCE CHECKED FOR SPILLAGE IN ACCORDANCE WITH THE METHOD DETAILED IN THESE INSTRUCTIONS.

HAND THESE INSTRUCTIONS TO THE USER.

## SERVICING NOTES

### **GENERAL NOTES**

SERVICING SHOULD BE CARRIED OUT ANNUALLY BY A COMPETENT PERSON SUCH AS A CORGI REGISTERED PERSON IN ACCORDANCE WITH THE RELEVANT REGULATIONS TO ENSURE THE SAFE AND CORRECT OPERATION OF THE APPLIANCE.

BEFORE COMMENCING ANY SERVICE OR REPLACEMENT OF PARTS TURN OFF GAS SUPPLY TO FIRE  
AFTER SERVICING CHECK FOR GAS SOUNDNESS

AT LEAST ONCE A YEAR CHECK FOR DEBRIS IN THE CATCHMENT AREA BEHIND THE FIRE AND FLUE WAY

IF SOOT HAS ACCUMULATED CHECK TO ESTABLISH CAUSE AND RECTIFY. IF NECESSARY CLEAN FLUE OR CHIMNEY ACCORDINGLY

EXAMINE THE COALS FOR SIGNS OF CRACKING AND REPLACE IF NECESSARY. SEE COAL LAYOUT PROCEDURE BEFORE ATTEMPTING TO REPLACE COALS, WHICH SHOULD ONLY BE REPLACED AS A COMPLETE SET WITH NO EXTRA COALS ADDED

#### **1 REMOVAL OF COALS**

REMOVE LOOSE COALS

REMOVE FRONT FIBRE BASE

REMOVE MAIN FIBRE BASE

#### **2 REPLACEMENT OF GAS CONTROL**

REMOVE COAL SET AS 1

DISCONNECT FIRE AT INLET ELBOW

REMOVE FIRE TRAY BY UNSCREWING TWO SCREWS AT FRONT BOTTOM SECTION OF FIRE TRAY

REMOVE CONTROL KNOB. DISCONNECT GAS CONNECTIONS TO VALVE INCLUDING PILOT CONNECTION AND THERMOCOUPLE CONNECTION

REMOVE LOCKNUT HOLDING GAS CONTROL TO FRONT BOTTOM SECTION

RE ASSEMBLE IN REVERSE ORDER

TURN ON GAS SUPPLY, CHECK FOR SOUNDNESS AND RE COMMISSION APPLIANCE

#### **3 REPLACEMENT OF INJECTOR**

REMOVE COALS SEE 1

REPEAT 2 REMOVE GAS CONTROL

DISCONNECT GAS CONNECTIONS TO INJECTOR

UNSCREW INJECTOR "B" WHILST AT SAME TIME HOLDING AERATOR CONTROL "A" WITH A SPANNER AND CLEAN OR REPLACE ( REMEMBER TO RESEAL INJECTOR ) **SEE DIAGRAM BELOW.**

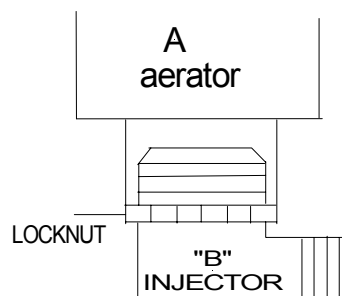

RE ASSEMBLE IN REVERSE ORDER  
TURN ON GAS SUPPLY. CHECK FOR SOUNDNESS AND RECOMMISSION THE APPLIANCE

**4 REPLACEMENT OF OXY-PILOT ASSEMBLY**

DISCONNECT FIRE AT INLET ELBOW  
REMOVE FIRE TRAY  
DISCONNECT THERMOCOUPLE FROM GAS VALVE  
DISCONNECT GAS CONNECTION FROM PILOT ASSEMBLY  
REMOVE IGNITOR LEAD FROM PILOT ASSEMBLY  
UNDO SCREWS SECURING OXY-PILOT TO FIRE TRAY  
RE-ASSEMBLE IN REVERSE ORDER  
TURN ON GAS SUPPLY, CHECK FOR GAS SOUNDNESS AND RE-COMMISSION APPLIANCE.

<b>CLEANING</b>
-----------------

**GENERAL INFORMATION.**

BEFORE CLEANING ANY PART OF THE FIRE, ENSURE THAT THE GAS IS TURNED OFF AND THE FIRE IS COLD.

**BLACK PAINT.** USE ONLY A CLEAN DAMP CLOTH. DO NOT USE ANY CLEANING AGENTS.

**BRASS TRIM.** USE BRASSO ENSURING THAT IT DOES NOT COME INTO CONTACT WITH THE BLACK PAINT FINISH. **IMPORTANT.** THE PAINT FINISH IS DURABLE AND HEAT RESISTANT, HOWEVER IT WILL BE DAMAGED IF PLASTER, CEMENT OR WALLPAPER PASTE COMES INTO CONTACT WITH IT.

**COALS AND CERAMICS.** IF FOR ANY REASON IT IS NECESSARY TO REMOVE CERAMIC PARTS, THEN BEFORE REPLACEMENT THE BURNER SHOULD BE CHECKED THAT NO PARTICLES HAVE DEPOSITED ON THE BURNER. IF NECESSARY VACUUM THEM CAREFULLY. THEN REFER TO INSTRUCTIONS FOR REPLACING THE CERAMICS.

**FRET INFORMATION**

**A STANDARD 16 " FRET IS SUITABLE TO SIT IN FRONT OF THE HEATRAVE S/L HOWEVER A MINIMUM FREE AREA REQUIREMENT MUST BE MET AS SHOWN BELOW.**

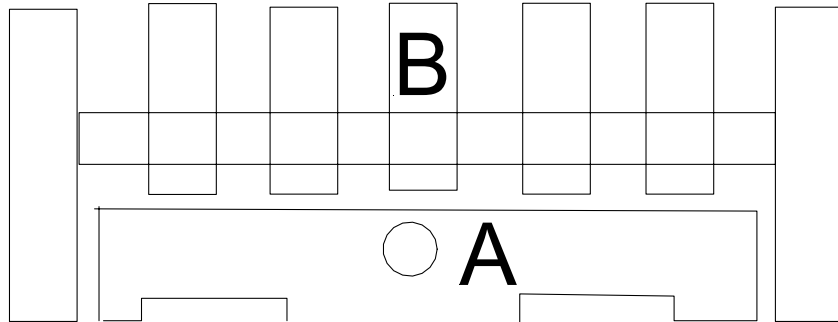

**MINIMUM FREE AREA FOR AIR FLOW  
ON ASH PAN COVER "A" = 30 CM<sup>2</sup>  
MINIMUM FREE AREA FOR AIR FLOW  
ON FRET "B" = 30 CM<sup>2</sup>**

**USER REPLACEMENT PARTS**

**CERAMIC SET CRY001S/L BRASS TRIM CRY002S/L  
GAS TAP CRY003S/L PIEZO IGNITOR CRY004S/L  
PILOT ASSEMBLY CRY005 S/L**



# USERS INSTRUCTIONS

## USERS INSTRUCTIONS YOUR DIAMOND GAS APPLIANCE

### IMPORTANT NOTES

YOUR DIAMOND IS A LIVE FUEL EFFECT GAS FIRE. DUE TO ITS NEWNESS THE FIRE MAY GIVE OFF A SLIGHT SMELL FOR A SHORT PERIOD AFTER INSTALLATION. THIS IS QUITE NORMAL AND WILL DISAPPEAR AFTER A FEW HOURS OF OPERATION.

THE APPLIANCE TO WHICH THESE INSTRUCTIONS APPLY MUST BE INSTALLED BY A COMPETENT PERSON (EG A C.O.R.G.I. MEMBER IN ACCORDANCE WITH THE CURRENT EDITION OF THE GAS SAFETY (INSTALLATIONS AND USE) REGULATIONS OR THE RULES IN FORCE) . IT MUST ALSO BE APPROVED BY THE HEALTH AND SAFETY EXECUTIVE AND MUST BE IN ACCORDANCE WITH THE INSTALLATION AND SERVICING INSTRUCTIONS SUPPLIED.

SERVICING SHOULD BE CARRIED OUT REGULARLY BY A COMPETENT PERSON (E G C.O.R.G.I MEMBER ) IN ACCORDANCE WITH THE CURRENT EDITION OF THE GAS SAFETY ( INSTALLATION AND USE) REGULATIONS OR THE FRULES IN FORCE. TO ENSURE THE CORRECT AND SAFE OPERATION OF THE APPLIANCE , DEBRIS SHOULD ALSO BE REMOVED FROM BNEHIND THE APPLIANCE AT REGULAR INTERVALS.

BEFORE INSTALLATION OF THE APPLIANCE THE CHIMNEY MUST BE THOROUGHLY SWEEPED AND THEN INSPECTED REGULARLY TO ENSURE THAT IT REMAINS FREE OF OBSTRUCTION.

A FIRE GUARD COMPLYING TO BS6539 OR BS6778 MUST BE FITTED IF THE ROOM WILL BE OCCUPIED BY YOUNG CHILDREN OR THE ELDERLEY OR INFIRM PEOPLE.

ON NO ACCOUNT MUST ANY RUBBISH BE THROWN ON TO THE FIRE , OR THE LAYOUT OF THE FIRE BED DISTURBED.

### CLEARANCES

#### SHELVES

MINIMUM CLEARANCE FROM HEARTH TO UNDERSIDE OF COMBUSTABLE SHELF MUST BE 800mm PROVIDED SHELF DEPTH IS 150mm OR LESS.

WHEN THE SHELF DEPTH IS INCREASED BY INCREMENTS OF 12.5mm GREATER THAN 150mm ADD 25mm TO THE 800mm MINIMUM CLEARANCE.

SOFT FURNISHINGS, DECORATIONS AND SOME WALL COVERINGS MAY DISCOLOUR OR SCORCH IF POSITIONED TOO CLOSE TO THE FIRE, BEAR THIS IN MIND WHEN REDECORATING.

### OPERATING INSTRUCTIONS

THE APPLIANCE DATA BADGE IS POSITIONED ON THE FRONT BOTTOM SECTION OF THE APPLIANCE AND CARRIES THE CONTROL KNOB POSITIONS, THE FULL LIGHTING PROCEDURE IS AS FOLLOWS.  
(SEE FIGURE . 1 )

1. PUSH CONTROL KNOB IN AS FAR AS POSSIBLE ON GAS CONTROL  
TURN KNOB ANTICLOCKWISE TO IGNITION POSITIONAS SHOWN IN FIG 1 STILL KEEPING KNOB PRESSED IN AS FAR AS POSSIBLE
2. PRESS IGNITION BUTTON ( AS SHOWN IN FIG 1 0 A COUPLE OF TIMES UNTIL PILOT LIGHT IGNITES THEN **KEEP THE KNOB PRESSED IN FOR 15 SECONDS** . IF THE PILOT FAILS TO LIGHT, TURN THE CONTROL KNOB CLOCKWISE TO THE OFF POSITION, WAIT 3 MINUTES AND REPEAT THE PROCEDURE.
3. WHEN THE PILOT FLAME IS ALIGHT THE CONTROL KNOB SHOULD BE ALLOWED TO SPRING OUT SLIGHTLY. TURN THE KNOB FULLY ANTICLOCKWISE TO THE HIGH POSITION. THE PILOT FLAME WILL THEN IGNITE THE MAIN BURNER , THE PILOT FLAME CAN BE VIEWED TO THE RIGHT OF THE FIRE JUST BEHIND THE FRONT COAL BED.

4. THE HEIGHT OF THE FLAMES CAN BE ADJUSTED BY TURNING THE CONTROL KNOB BETWEEN THE LOW AND HIGH POSITIONS, NOTE THAT THE KNOB SLOTS IN POSITION AT THE LOW AND HIGH POSITIONS AND MUST BE PUSHED IN SLIGHTLY BEFORE IT IS TURNED.
5. TO TURN THE FIRE OFF, DEPRESS THE KNOB SLIGHTLY AND TURN IT TO THE PILOT POSITION.
6. TO COMPLETELY EXTINGUISH THE FIRE DEPRESS THE KNOB SLIGHTLY AND TURN TO THE OFF POSITION.
7. SHOULD THE SPARK IGNITION FAIL TO OPERATE, TURN THE CONTROL KNOB TO THE OFF POSITION AND WAIT 3 MINUTES. TURN THE KNOB TO THE IGNITION POSITION AND THEN LIGHT THE PILOT WITH A TAPER. (SEE FIG 2 ) “ LIGHTING WITH A TAPER IS AN EMERGENCY MEASURE AND THE APPLIANCE SHOULD BE SERVICED AS SOON AS POSSIBLE .” AND THEN PROCEED AS STATED IN PARAGRAPHS 2/7 .

**IMPORTANT: THIS APPLIANCE IS FITTED WITH AN OXYGEN DEPLETION SENSOR INCORPORATED INTO THE PILOT BODY. SHOULD THE FIRE REPEATEDLY EXTINGUISH ITSELF THEN SPECIALIST ADVICE SHOULD BE SOUGHT, AS THIS MAY INDICATE SPILLAGE INTO THE ROOM OF COMBUSTION PRODUCTS.**

## AMMENDMENT SHEET FOR TAP/PIEZO COMBINED MODEL

### **OPERATING INSTRUCTIONS**

THE APPLIANCE DATA BADGE IS POSITIONED ON THE FRONT BOTTOM SECTION OF THE APPLIANCE AND CARRIES THE CONTROL KNOB POSITIONS, THE FULL LIGHTING PROCEDURE IS AS FOLLOWS.

(SEE FIG 1 )

1. PUSH CONTROL KNOB IN AS FAR AS POSSIBLE ON GAS CONTROL
2. TURN KNOB ANTICLOCKWISE TO IGNITION POSITION AS SHOWN IN FIG 1 STILL KEEPING KNOB PRESSED IN AS FAR AS POSSIBLE.
3. THE IGNITION BUTTON WILL IGNITE THE PILOT WITH THIS OPERATION. **KEEP THE KNOB PRESSED IN FOR 15 SECONDS.** IF THE PILOT FAILS TO LIGHT TURN THE CONTROL KNOB CLOCKWISE TO THE OFF POSITION. WAIT 3 MINUTES AND REPEAT THE PROCEDURE.
4. WHEN THE PILOT FRAME IS ALIGHT THE CONTROL KNOB SHOULD BE ALLOWED TO SPRING OUT SLIGHTLY . TURN THE KNOB FULLY ANTICLOCKWISE TO THE HIGH POSITION. THE PILOT FLAME WILL THEN IGNITE THE MAIN BURNER . THE PILOT FLAME CAN BE VIEWED TO THE RIGHT OF THE FIRE JUST BEHIND THE FRONT COAL BED.
5. THE HEIGHT OF THE FLAMES CAN BE ADJUSTED BY TURNING THE CONTROL KNOB BETWEEN THE LOW AND HIGH POSITIONS AND MUST BE PUSHED IN SLIGHTLY BEFORE IT IS TURNED.
6. TO TURN THE FIRE OFF, DEPRESS THE KNOB SLIGHTLY AND TURN IT TO THE PILOT POSITION.
7. TO COMPLETELY EXTINGUISH THE FIRE , DEPRESS THE KNOB SLIGHTLY AND TURN TO THE OFF POSITION.
8. SHOULD THE SPARK IGNITION FAIL TO OPERATE, TURN THE CONTROL KNOB TO THE OFF POSITION AND WAIT 3 MINUTES. TURN THE KNOB TO THE IGNITION POSITION AND THEN LIGHT THE PILOT WITH A TAPER. (SEE FIG 2 ). “ LIGHTING WITH A TAPER IS AN EMERGENCY MEASURE AND THE APPLIANCE SHOULD BE SERVICED AS SOON AS POSSIBLE.” AND THEN PROCEED AS STATED IN PARAGRAPHS 2/7.

**IMPORTANT: THIS APPLIANCE IS FITTED WITH AN OXYGEN DEPLETION SENSOR INCORPORATED INTO THE PILOT BODY. SHOULD THE FIRE REPEATEDLY EXTINGUISH ITSELF THEN SPECIALIST ADVICE SHOULD BE SOUGHT, AS THIS MAY INDICATE SPILLAGE INTO THE ROOM OF COMBUSTION PRODUCTS.**

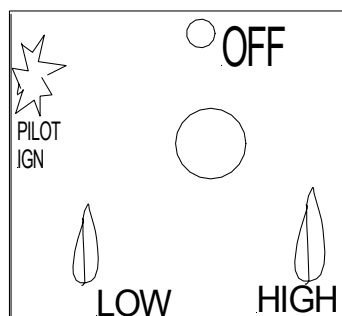

## CLEANING

### GENERAL INFORMATION.

BEFORE CLEANING ANY PART OF THE FIRE, ENSURE THAT THE GAS IS TURNED OFF AND THE FIRE IS COLD.

**BLACK PAINT.** USE ONLY A CLEAN DAMP CLOTH. DO NOT USE ANY CLEANING AGENTS.

**BRASS TRIM.** USE BRASSO ENSURING THAT IT DOES NOT COME INTO CONTACT WITH THE BLACK PAINT FINISH.

**IMPORTANT.** THE PAINT FINISH IS DURABLE AND HEAT RESISITANT, HOWEVER IT WILL BE DAMAGED IF PLASTER, CEMENT OR WALLPAPER PASTE COMES INTO CONTACT WITH IT.

**COALS AND CERAMICS.** IF FOR ANY REASON IT IS NECESSARY TO REMOVE CERAMIC PARTS , THEN BEFORE REPLACEMENT THE BURNER SHOULD BE CHECKED THAT NO PARTICLES HAVE DEPOSITED ON THE BURNER. IF NECESSARY VACUUM THEM CAREFULLY, THEN REFER TO INSTRUCTIONS FOR REPLACING CERAMICS. THE COAL EFFECT LAYOUT MUST NOT BE ALTERED AND ONLY THE PIECES SUPPLIED MUST BE USED.

### FRET INFORMATION

A STANDARD 16 “ FRET IS SUITABLE TO SIT IN FRONT OF THE HEATRAVE S/L , HOWEVER A MINIMUM FREE AREA REQUIREMENT MUST BE MET AS SHOWN BELOW.

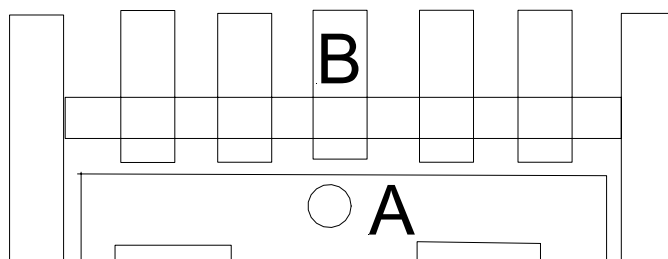

**MINIMUM FREE AREA FOR AIRFLOW  
ON ASH PAN COVER “A” = 30CM<sup>2</sup>  
MINIMUM FREE AREA FOR AIR FLOW  
ON FRET “ B “ = 30 CM<sup>2</sup>**

### USER REPLACEMENT PARTS

CERAMIC SET	CRY001DIAM
BRASS TRIM	CRY002DIAM

ISSUE 1

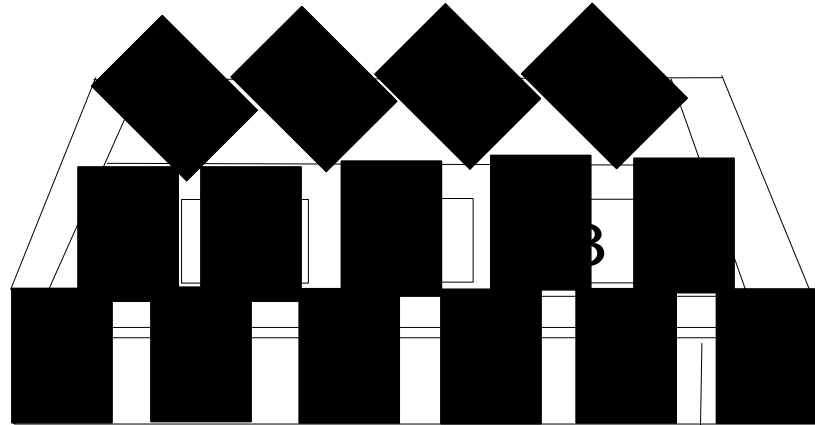

# TAPER

TO LIGHT WITH A TAPER, PUSH LIGHTED TAPER TOWARDS PILOT LIGHT AS SHOWN ABOVE WHILST FOLLOWING OPERATING INSTRUCTIONS.

**COAL BED LAYOUT**

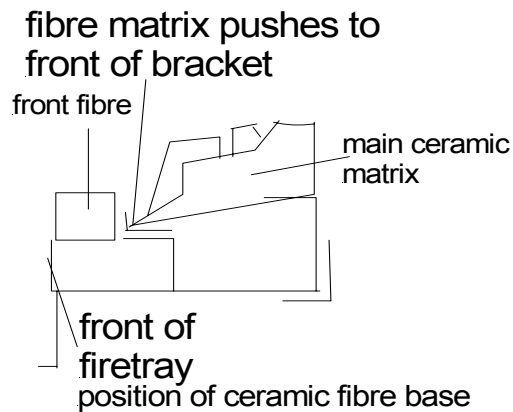

PERIODICALLY SMALL DEPOSITS OF SOOT MAY GATHER ON THE COALS AND BURNER. THIS MUST BE REMOVED BY REMOVING COALS, AND BRUSHING OR VACUUMING ANY DEPOSITS, THEN REPLACE COALS USING THE FOLLOWING PROCEDURE.

**DIAMOND RANDOM FUEL LAYOUT**  
**SLIMLINE RANDOM FUEL PIECES LAYOUT**  
**(ALSO COMES IN GREY AND BUFF COLOURS)**



SIX RANDOM FUEL PIECES SIT AS SHOWN ON TOP OF FRONT FIBRE PIECE.  
NOTE: THEY MAY HAVE TO BE TURNED SLIGHTLY TO ENSURE ENOUGH ROOM  
IS AVAILABLE FOR THEM ALL TO FIT CORRECTLY



THE NEXT FOUR FUEL PIECES SIT ON TOP OF FIRST PIECES AS SHOWN SITTING  
BETWEEN EACH OF THE FRONT PIECES



FINAL MIDDLE PIECE IS FITTED TO RIGHT  
FOUR RANDOM FUEL PIECES SIT AS SHOWN BETWEEN THE MIDDLE RANDOM FUEL  
PIECES FINISHING THE LAYOUT



